

Islanded grid operation and restoration in electricity distribution networks following large-scale natural hazards

Nirmal Nair, Duncan Maina, Samad Shirzadi, Rodger Griffiths, Cosmin Cosma



Method

Depending on the various Simulated earthquake trajectories, different islanded grid scenarios are probable. The islands can be as a result of generators riding through the disaster event thus not shutting down, continuing to supply power to local loads without interruption. The islands can also be as a result of generators shutting down, then re-energizing the distribution network to feed the local loads.

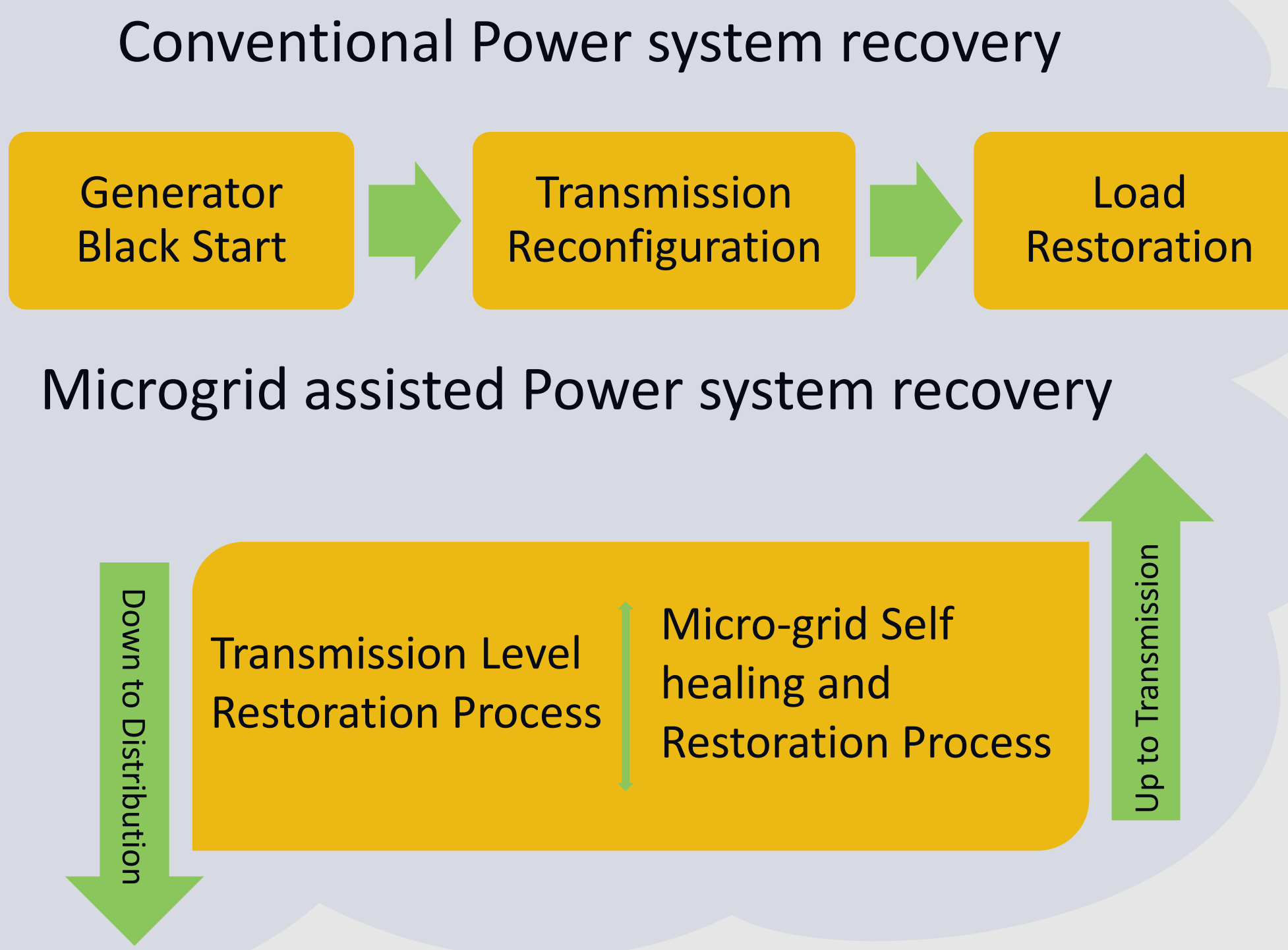

Resilience

the ability to prepare for and adapt to changing conditions and withstand and recover rapidly from disruptions. Also includes the ability to withstand and recover from deliberate attacks, accidents, or naturally occurring threats or incidents.

Challenges

1, 2, 3, 4

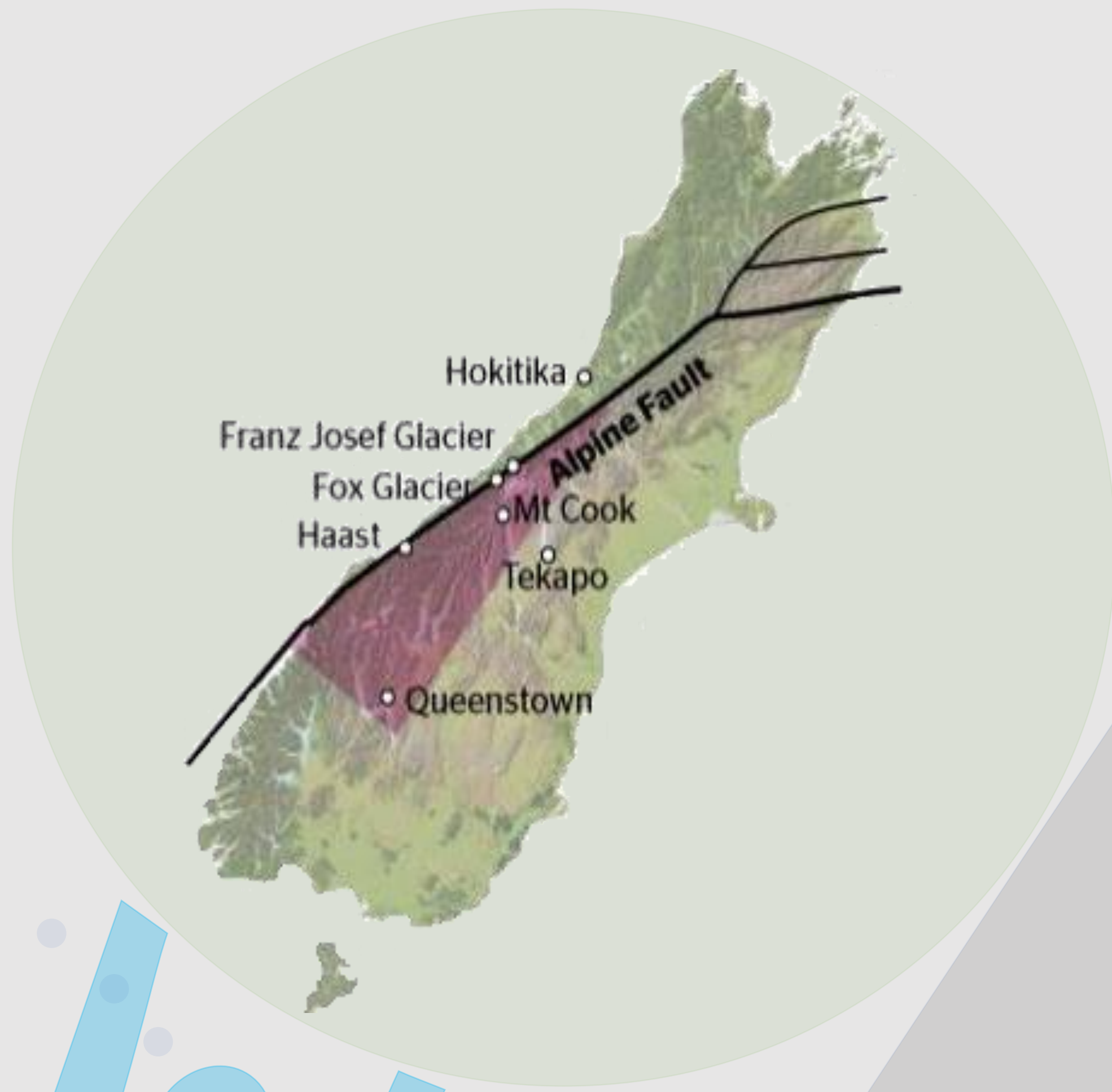

West Coast Project

This project assumes the occurrence of the AF8 earthquake splitting the Westcoast network into multiple segments. If the segments have available DGs (and connection to grid is unavailable due to the damage), then they can supply power to the vicinity loads while waiting for the repairs to be undertaken. The aim of this project is to investigate the islanding and restoration capability of the Westcoast network operated by Westpower.

4 Reconnection

Re-connection of the formed islands to each other and to the grid requires proper strategy to avoid system re-collapse.

3 Control & Protection

Different voltage / frequency control strategies and protection schemes are required for different islanding scenarios.

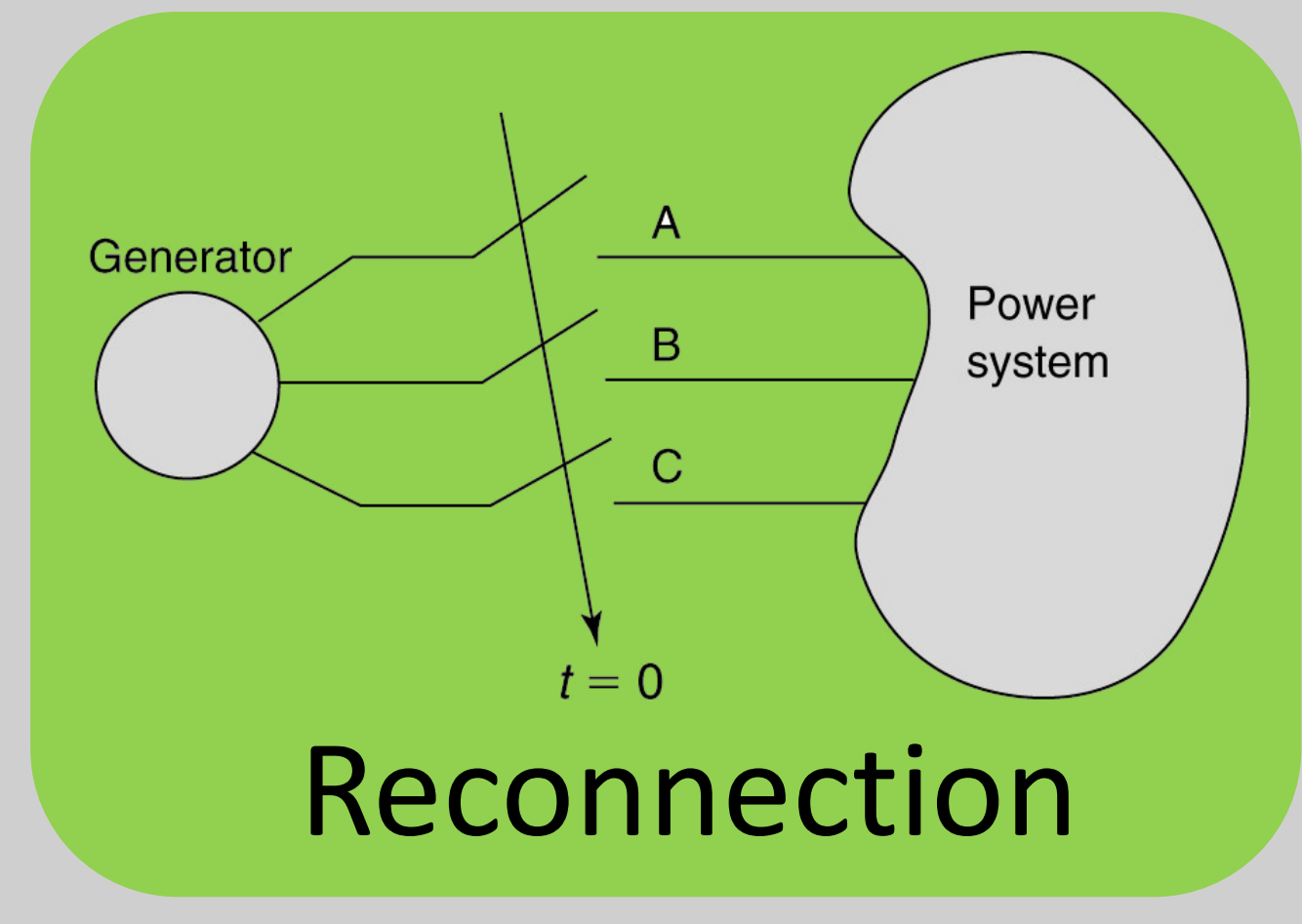

2 Generator Stability

Rotor angle stability of the generators in the low inertia islanded grids is a challenge specially in a network designed to operate in grid connected mode.

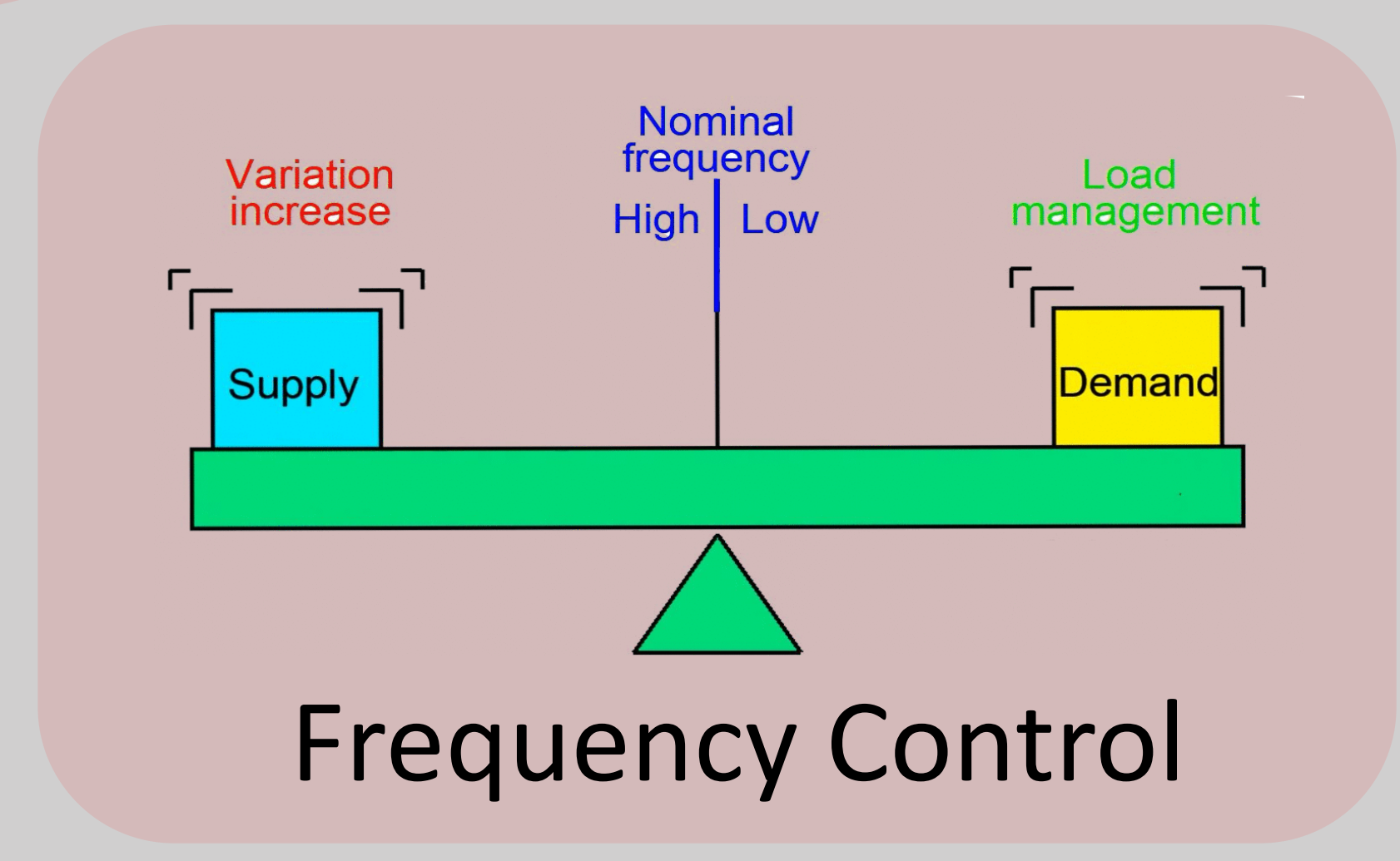

1 Islanding Detection

Islanding detection is possible through either local or remote methods. Remote methods rely on communication. PMU-based techniques as communication-based techniques are getting more attractive by redeeming their deployment costs for their good technical performance

